

ARCHITECTURAL GRILLES & VISION BARRIERS

# PATTERNS *of* INSPIRATION





ARCHITECTURAL GRILLES & VISION BARRIERS

---

# PATTERNS *of* INSPIRATION



# Let the colors, shapes and textures of Construction Specialties Architectural Grilles and Vision Barriers inspire your next design.

Architectural Grilles and Vision Barriers by Construction Specialties have been capturing the imaginations of architects by adding **depth** and **dimension** to buildings for more than 50 years. **Both functional and decorative**, architectural grilles and vision barriers can change the entire personality of a building. Turn a wall from drab to dramatic. Conceal mechanicals in plain sight with bold shapes and colors. Make a parking

garage memorable. The possibilities are endless. And with 25 different patterns and **unlimited color options**, there's at least one Construction Specialties Architectural Grille or Vision Barrier that's sure to inspire you.

**Contact us today at 800.631.7379 to talk about your next project.**

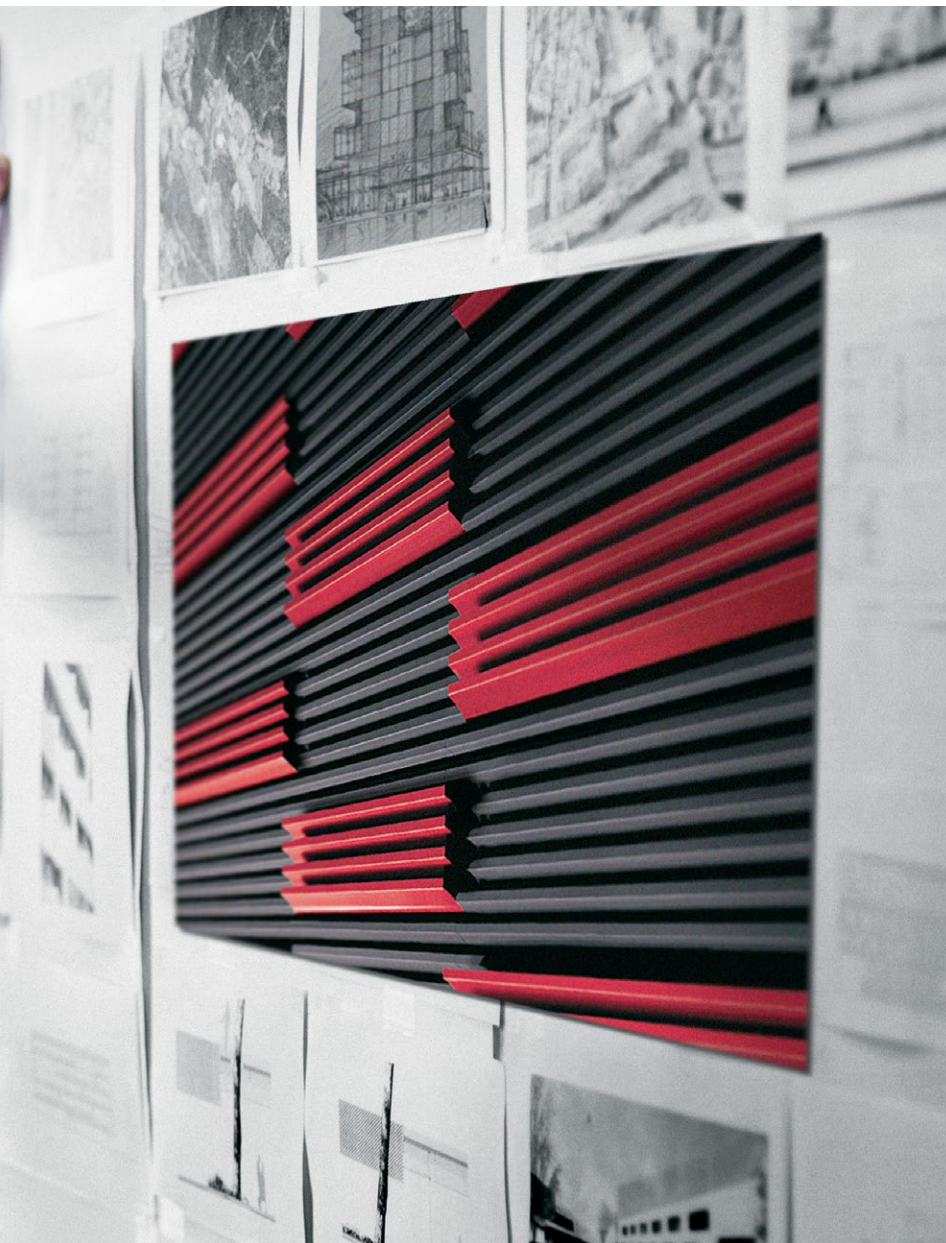

Bold Line  
Screening Systems

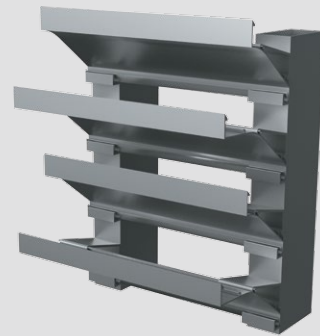

## Defy boring

Add exciting color, dimension and **texture** to parking garages, mechanical equipment barriers and virtually any screenwall project.

SEE PAGE 20 FOR MORE DETAILS.



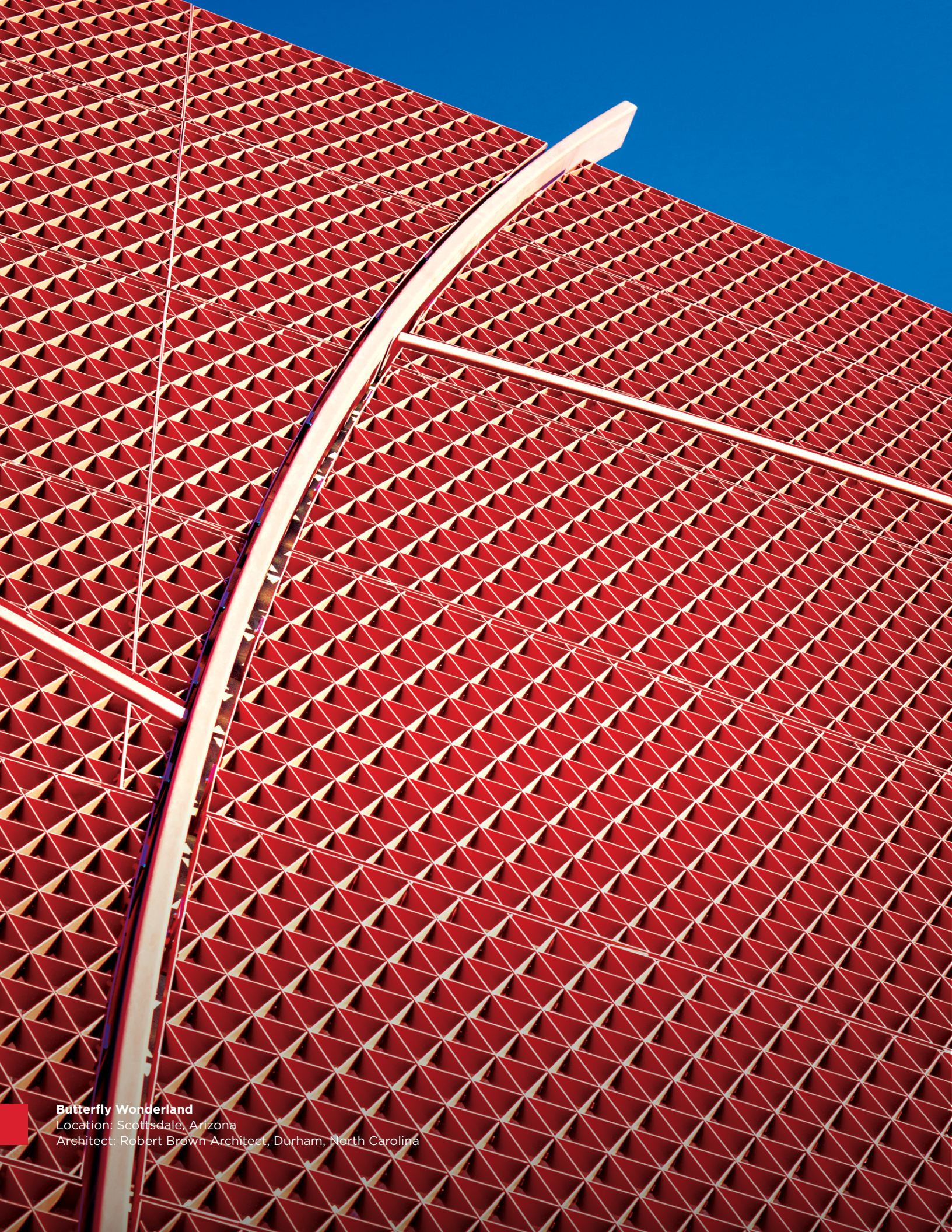

**Butterfly Wonderland**

Location: Scottsdale, Arizona

Architect: Robert Brown Architect, Durham, North Carolina



Butterfly Wonderland

# Drama emerges in three dimensions



The exterior design for Butterfly Wonderland had to impart the sense of wonder and whimsy that would befit America's largest butterfly atrium. Although the original specifications called for a basic perforated mesh sheet metal for the building's façade, the architects determined that the product was too one-dimensional and did not add enough depth or texture.

They chose Construction Specialties' **Marquis Geometric Grille** with a custom powder coat finish to complement the brick walls and provide the right balance between the heavy metal asymmetrical accents and patterns. This **challenging installation** required our engineering team to design a grid system for an entire wall that could be mounted and accessed only from the front.

Geometric grilles enabled the atrium's metamorphosis by transforming the entire façade.

## Product Marquis

The Marquis' pattern of X's and diamonds, along with asymmetrical accents, adds texture, drama and visual interest that changes with the movement of the sun and the angle at which it is viewed.

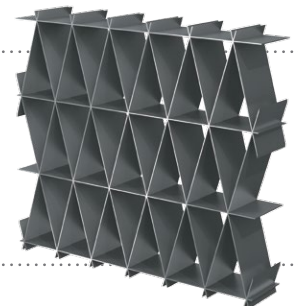



# PATTERNS of INSPIRATION

Wichita Area Technical College  
National Center for Aviation

## Beauty and grace take flight

When the architects wanted a **linear profile** to give this airline pilot training facility a more modern, aeronautic aesthetic, they chose Construction Specialties' Vert-A-Cade 304. The product's thin blade profile adds **visual interest** and provides clear, **open sightlines**.

The contoured grilles provide an appealing contrast to the wing-shaped roofline, yet blend harmoniously with the wide expanses of glass, adding a light, airy and inviting appearance. The horizontal blades have an added bonus of helping to **reduce sun glare and heat gain** like a sunshade.

The blade profile adds a strong, metal-dominant exterior that gets its lift from clean, graceful lines.



### **Product** Vert-A-Cade 304

Although traditionally used on rooftops as a vision barrier for mechanical equipment, the Vert-A-Cade line is graceful enough to hang with the decorative grilles. Manufactured from extruded aluminum in numerous blade styles, the Vert-A-Cade line is long-lasting, cost-effective and attractive, and requires little maintenance.

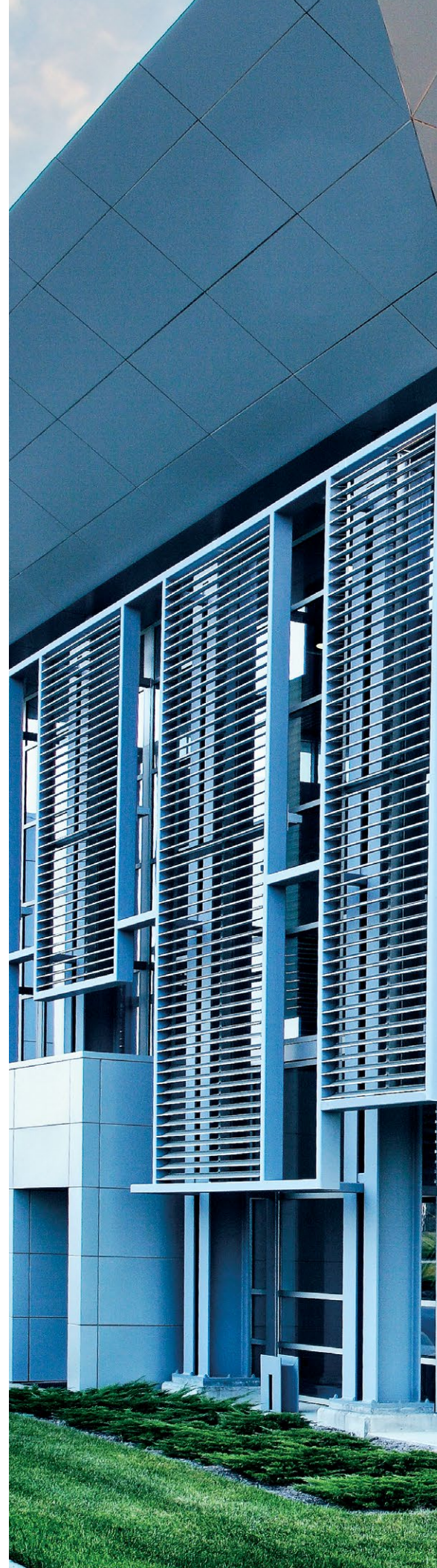



**WATC - National Center for Aviation**  
Location: Wichita, Kansas  
Architect: Schaeffer Johnson Cox Frye







**Consolidated Rental**

Location: Fort Lauderdale, Florida

Architect: Spillis Candela DMJM, Coral Gables, Florida



Consolidated Rental

## Parking garage as artwork

Florida state code says that parking structures must not look like parking structures. The architect took that requirement one step further by using standard architectural grille products in custom orientations to construct a parking garage that looks more like urban sculpture.

Three Construction Specialties Architectural Grille products combine to provide varying **widths, depths** and **free area** for adequate air exchange. The horizontal and vertical installation

of more than 100,000 feet of decorative grilles adds a clean, **artistic** and three-dimensional aesthetic to what otherwise would be bare concrete.

Many of our grilles are well-suited for parking structures because of their **ventilation and vision control** properties. And we have extensive experience designing screening systems to satisfy specific parking garage **code requirements**, such as free area, seismic load and fire resistance.



With decorative grilles, you may never look at a parking garage the same way again.



### **Products** Vert-A-Cade 8000, Vert-A-Cade 304, Myriad Continuous

The Vert-A-Cade line is ideal for parking garages because its A-shaped profile adds strength, which translates into excellent spanning ability—more than double that of most profiles. Vert-A-Cade parking screens can extend up to 12 feet, requiring no extra steel supports between the openings of each deck.



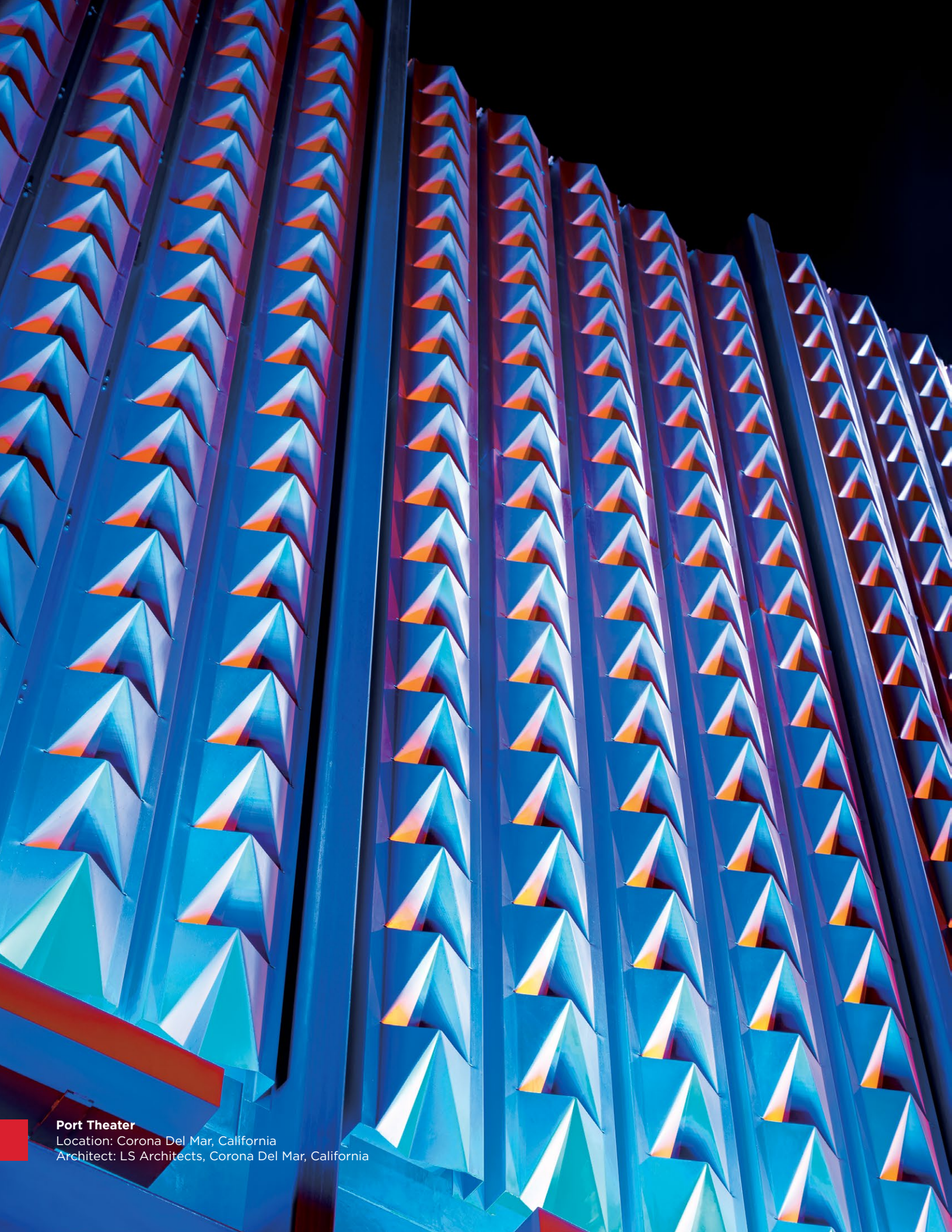

**Port Theater**

Location: Corona Del Mar, California

Architect: LS Architects, Corona Del Mar, California



Port Theater

## A fresh new face

The Port Theater, which opened in the '50s, was slated for demolition in the '90s before a renovation and refurbishment recently returned the building to its former splendor—and then some. And what better way to show a flair for the dramatic than through one of Construction Specialties' most **daring** and **dimensional grille** profiles: Alumatex Tweed.

By day, 12-inch-wide silver powder-coated vertical columns of Alumatex Tweed defy the mainstream with three-inch-deep triangular patterns. By night, trays of blue LED pocket lights illuminate the columns from below to transform the colors running upward and cast **theatrical shadows**.

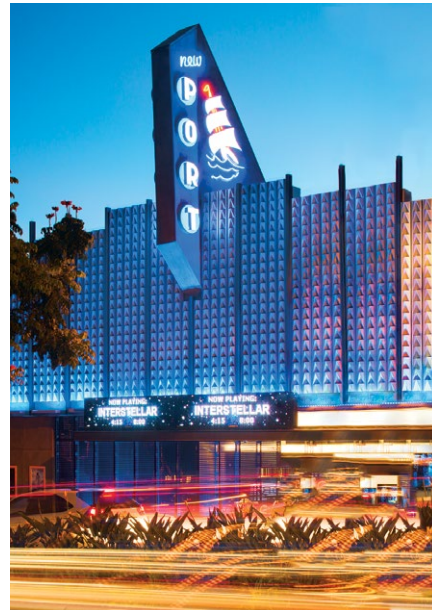

The combination of texture and light create a Pacific Coast star that's ready for its close-up.

---

### Product Alumatex Tweed

With its strong, angular shape, Alumatex Tweed—and its sister product Alumatex Madras—can span up to 12 feet deep in vertical panels with minimal rear substructure needed. Reduced substructure means less weight and less labor, which add up to a cost-effective way to add texture and span.

---

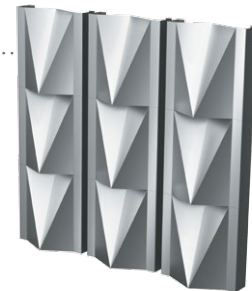





**Vista Grande**

Location: Miami, Florida

Architects: Corwil Architects Inc., Coral Gables, Florida



Vista Grande Apartments

## Brand new goes retro

Architectural grilles and panels make this new construction project fit right in with the established buildings in the vibrant, quirky Miami Modern district. A **soft, subtle** line of Vert-A-Cade 304 vertical blades with bright- and pastel-colored horizontal panels add **visual interest** that separates the parking garage from the residential apartments above.

Adding to the **on-trend design** of the screenwall is its dual **tilt angles** that pitch the structure up and out, which required our engineers to create a **custom-designed substructure**.

Vertical blades and colored panels add a fun, youthful vibe that help make this senior high-rise a cool place to live.



### Product Vert-A-Cade 304

With its soft, subtle line and high free area, the Vert-A-Cade line never looks heavy, always allows adequate ventilation and provides both horizontal and vertical orientations with a wide variety of blade depths and angles. Conceal or reveal—it's completely up to you.



Bill & Melinda Gates Computer Science Complex  
and Dell Computer Science Hall

## Smart design to inspire smart people

What's a more appropriate design to stimulate the intellectual pursuits of computer science researchers, faculty and students than a building that's light, open and **linear**? The architect selected Construction Specialties' Modular grille in a burnt orange finish to provide a **geometric accent** that enhances the Spanish-Mediterranean flavor of the building's cast limestone and Texas brick.

More **subtle** than a traditional sun shade product but just as effective, the open-cell Modular screens add a **contemporary** flair while offering protection from the intense Texas sunshine, contributing to the building's LEED silver rating for sustainable

design. The complex's primary gathering place is a spectacular five-story glass atrium with wood finishes and a grand staircase, complemented by the dramatic interior views of the **light-diffusing grilles** that cast **evocative shadows** throughout the day.



Outside-the-box thinking provided the algorithm for pairing beauty with functionality in this creative application.

---

### Product Modular

Offering varying depths for both the horizontal and vertical blades, Modular can be customized for a unique aesthetic that will provide any amount of light—or shade—you desire.

---

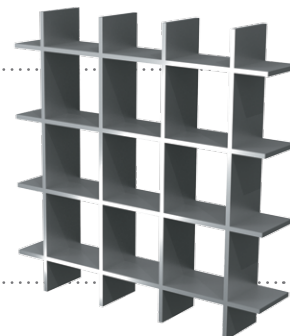





**Bill & Melinda Gates Computer Science Complex  
and Dell Computer Science Hall**  
Location: Austin, Texas  
Architect: Pelli Clarke Pelli Architects,  
New Haven, Connecticut/STG Design, Austin, Texas



# GEOMETRIC GRILLES

Construction Specialties Geometric Grilles give you **countless options** for expressing your design vision with **patterns, colors and customization**. Grilles also provide a beautiful, environmentally responsible and economic alternative for renovating existing building façades. Grilles come as a completely engineered linear blade system that mounts to any surface, allowing you to cover glass, brick, concrete or any façade while allowing light and air to filter through. They're equally beautiful as **decorative detailing** or as functional sun shading.

## Circular

This distinctive grille creates a bold visual statement on any building. Available in a 30° slope, or select a 45° slope for higher screening characteristics.

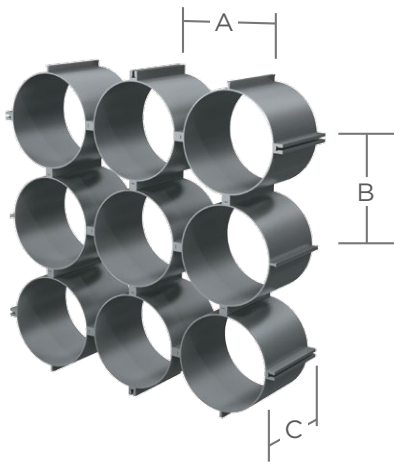

### Dimensions

- A:** Cell height: 6" on center
- B:** Cell width: 6" on center
- C:** Cell depth: 4"

## Lattice

Intersecting blades create a lattice effect. Blade spacing can be varied to change pattern, or grille can be rotated at 45° angle for a totally different effect. Wide selection of frames available.

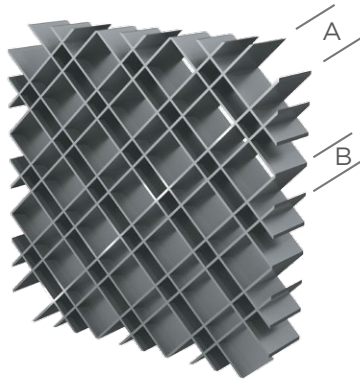

### Dimensions

- A:** Spacing between rows: 3" to 12"
- B:** Spacing of double blades: 2" minimum
- Blade thickness: 0.125"

## Marquis

The Marquis' diamond pattern with interlocking bar grilles can be used in a wide range of architectural applications and is available in a variety of sizes and depths.

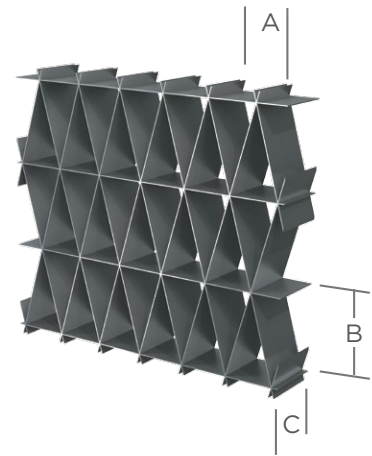

### Dimensions

- A:** Cell width: 7" to 16"
- B:** Cell height: 2" to 6"
- C:** Cell depth: 2" to 6"
- Bar thickness: 0.081" and 0.125"



For design, technical or engineering assistance, contact our design team.  
Download CAD details and specs for each grille at [www.c-sgroup.com/grilles/geometric](http://www.c-sgroup.com/grilles/geometric).

### Medallion

The Medallion decorative grille is available in various tube sizes and with round or square rosettes at the center. Specify individual or multiple medallions in a single frame. Grille features conceal welded construction.

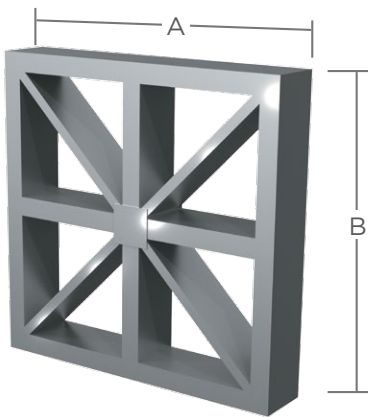

#### Dimensions

- A:** Cell width: 1' to 7'
- B:** Cell height: 1' to 7'

### Modular

Modular features customizable squares and rectangles in countless module sizes and depths.

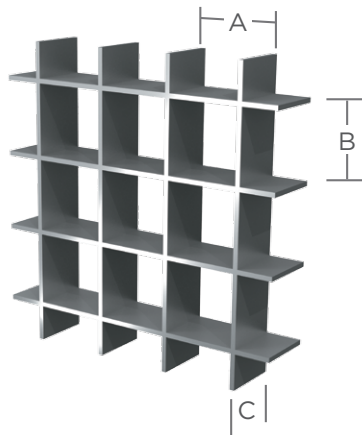

#### Dimensions

- A:** Cell width: 2" to 12"
- B:** Cell height: 2" to 12"
- D:** Cell depth: 2" to 6"

Blade tilt: 0° to 45°

Interlocking bars thickness:  
0.081" and 0.125"

### Modular Bold Line

The Modular Bold Line is a T-bar grille that creates bold shadow lines and serves as an excellent decorative screen.

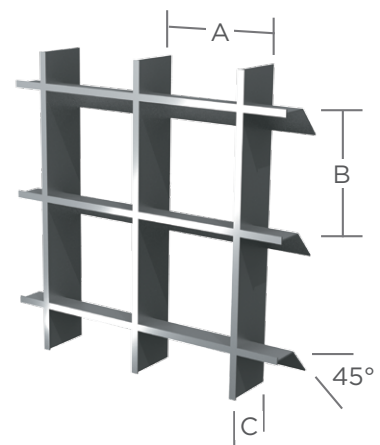

#### Dimensions

- A:** Cell width: 3" to 12"
- C:** Cell height: 3" to 12"
- B:** Cell depth: 3"

Blade width: 0.375" 45° tilt



### Myriad Continuous

This structurally sound continuous bar grille with variable blade tilt offers excellent sight cut-off. Increase mullion depth for greater span.

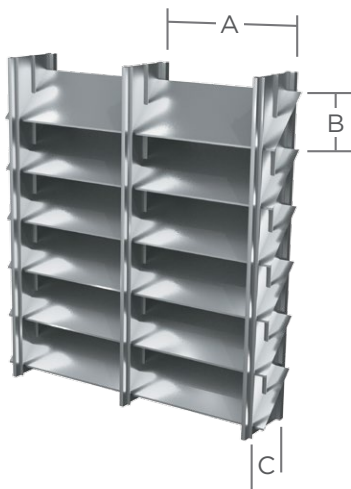

**Dimensions**

- A:** Cell width: 4" to 12"
- B:** Cell height: 2" to 12"
- C:** Cell depth: 2.5"  
Varies based on wind loading requirements

Blade depth: 1.5"  
Blade tilt: 0° to 45°

### Myriad Diamond

Excellent as a vision barrier or decorative grille, Myriad Diamond is offered in many cell sizes and shapes. Specify contrasting finishes on blades or mullions to create dramatic effects.

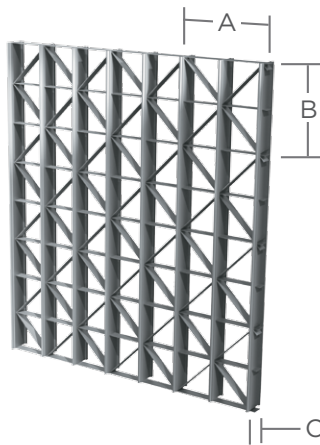

**Dimensions**

- A:** Cell width: 4" to 12"
- B:** Cell height: 4" to 12"
- C:** Cell depth: 3.75"  
Varies based on wind loading requirements

Blade thickness: 0.081"  
Frame thickness: 0.125"

### Myriad Staggered

Myriad Staggered features a pronounced vertical mullion with staggered horizontal blades that can be customized in length and angle to create dramatic shadows. Choose Myriad Staggered when a more visually distinct pattern is desired.

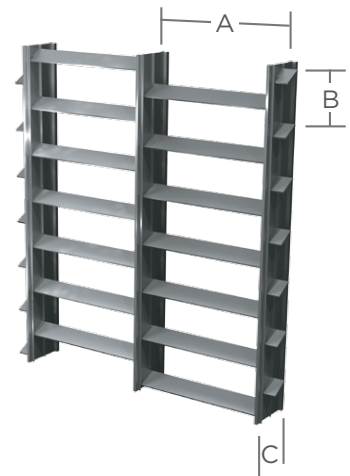

**Dimensions**

- A:** Cell width: 4" to 12"
- B:** Cell height: 2" to 12"
- C:** Cell depth: 2.5"  
Varies based on wind loading requirements

Blade depth: 1.5"  
Blade tilt: 0° to 45°



## Myriad XXX

A distinctive grille, Myriad XXX features adjustable cell spacing and mullion depths and is designed for sight cut-off or to screen solar rays. The 12-inch by 12-inch pattern is a dramatic yet economical screening system.

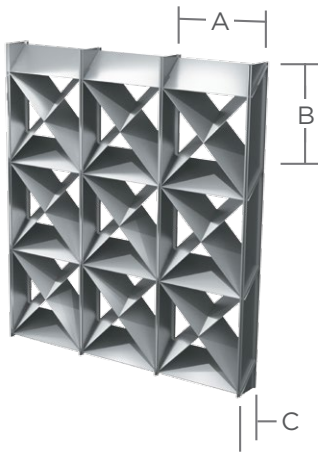

### Dimensions

- A:** Cell width: 4" to 12"
- B:** Cell height: 2" to 12"
- C:** Cell depth: 3.75"

Blade thickness: 0.081"  
Frame thickness: 0.125"  
Blade tilt: 0° to 45°

## Perform

Sturdier than wire mesh screening systems, the Perform offers a similar aesthetic with many pattern options, including round or square holes; round or square end slots; and straight or staggered rows.

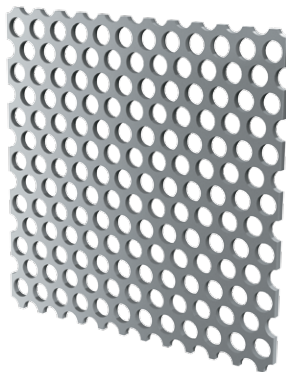

### Dimensions

Maximum dimensions  
in one direction: 48"

## Sentry

Sentry is an excellent security grille offered in aluminum with an optional stainless steel core that can be added for extra strength. Increase strength and spanning capability by altering the grille's cell size and depth.

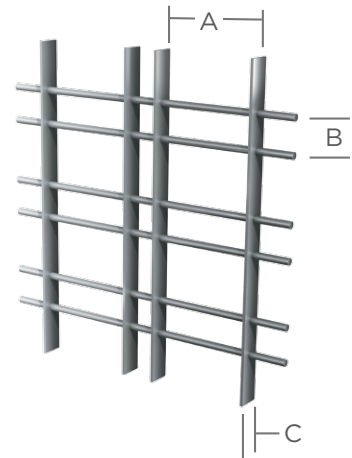

### Dimensions

- A:** Cell width: 3" to 12"
- B:** Cell height: 3" to 6"
- C:** Cell depth: 2"



# VISION BARRIER SCREENS

Specify a Construction Specialties Vision Barrier design anywhere you need **sight screening** or a horizontal or vertical **accent wall**. Our rugged aluminum screen patterns are ideal for use on parking garages to shield automobile headlights and satisfy requirements for **free area movement**, and they provide **excellent spanning ability** to accommodate multiple-level decks. We offer a variety of linear extruded aluminum profiles to conceal mechanical equipment with style and color. Used on or at ground level, vision barriers **integrate beautifully** into the building's architecture. Varied height, width and blade spacing of each pattern provide unlimited options.

## Alumatex Madras

A great parking deck screen, Alumatex Madras is available in lengths to 20 feet and all painted finishes.

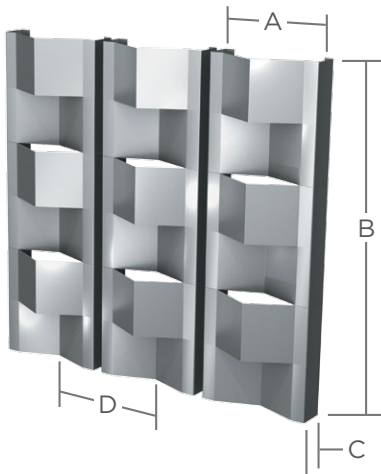

### Dimensions

- A:** Panel width: 12"
- B:** Panel height: 12' lengths
- C:** Panel depth: 3"
- D:** Panel spacing: 13" on center

Panel thickness: 0.04"  
Panel openings: 4" to 12"

**Free Area:** 12.5%

## Alumatex Tweed

Alumatex Tweed is an attractive, economical facing panel perfect for refacing applications and parking garages. Available in lengths to 20 feet, this grille is available in any architectural finish.

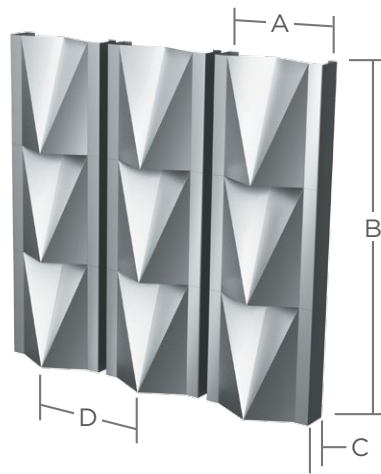

### Dimensions

- A:** Panel width: 12"
- B:** Panel height: 12' lengths
- C:** Panel depth: 3" inches
- D:** Panel spacing: 13" on center

Panel thickness: 0.04"

**Free Area:** 12.5%

## Econoscreen® RF-20

Econoscreen RF-20 features economical 0.020-inch thick roll-formed aluminum blades in any painted finish. Blades install on 0.081-inch support runners that span up to 6 feet at 20 p.s.f.

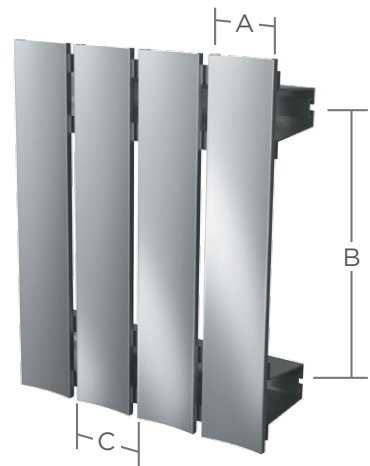

### Dimensions

- A:** Blade width: 3.5"
- B:** Varies based on wind loading requirements
- C:** Blade spacing: 4" on center

Blade thickness: 0.02"

**Free Area:** 10%



Contact our design team to help you select the right product to meet your project's coverage, free area and screening requirements. Download CAD details and specs for each grille at [www.c-sgroup.com/grilles/vision-barriers](http://www.c-sgroup.com/grilles/vision-barriers).

### Econoscreen® RV-20

Perfect for rooftop enclosures, Econoscreen RV-20 is an easy-to-install, economical screening choice available in all finishes.

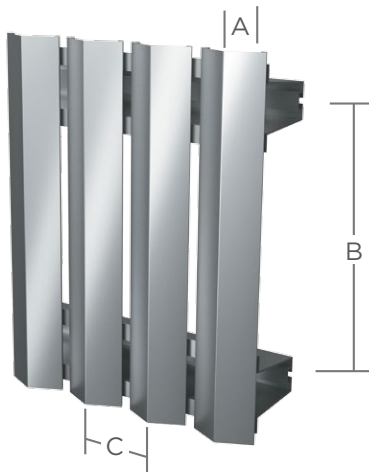

#### Dimensions

- A:** Blade depth: 1.5"
  - B:** Varies based on wind loading requirements
  - C:** Blade spacing: 4" on center
- Blade thickness: 0.02"

**Free Area:** 10%

### EL-160 and EL-240

Our two prefabricated EL Series screens offer a quick, economical way to conceal structures. The EL-160 provides a sleek look with maximum hiding capabilities. The EL-240 is more open for better line of sight.

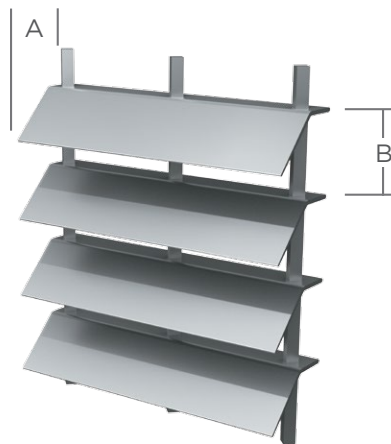

#### Dimensions

- A:** Blade depth: 2.5"
- B:** Blade spacing: EL-160 1.57"  
EL-240 2.36"

**Free Area:** EL-160 59%  
EL-240 65%

### Vert-A-Cade® 201 and 301

This horizontal screen is our most economical extruded vision barrier and is ideal for use on rooftop equipment and parking decks.

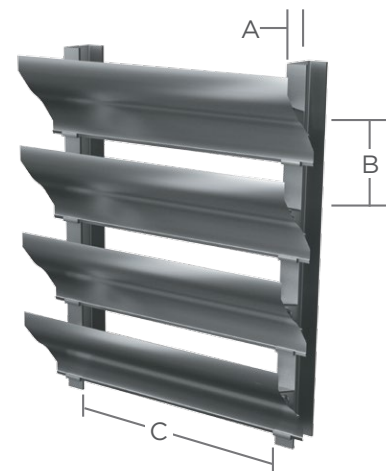

#### Dimensions

- A:** Blade depth for VAC 201: 2"  
Blade depth for VAC 301: 4"
- B:** Blade spacing for VAC 201: 2" on center  
Blade spacing for VAC 301: 6.75" on center
- C:** Varies based on wind loading requirements

**Free Area:** VAC 201 48%  
VAC 301 50%



## VISION BARRIER SCREENS

### Bold Line

Bold Line adds drama to any screening system by allowing different blade depths and multiple colors, while providing high free area.

#### Dimensions

Blade depth: 4" with the Bold Blade being 6"  
Blade spacing: 4" on center

**Free Area:** 58%

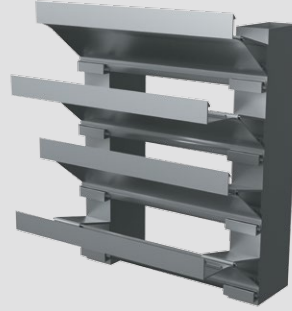

### Vert-A-Cade® 304

The VAC 304 horizontal screen provides high-performance free area with sight cut-off, with deep blades that create a heavy shadow line.



#### Dimensions

**A:** Varies based on wind loading requirements  
**B:** Blade spacing: 4.75"  
**C:** Blade depth: 6"

Blade thickness: 0.081"

**Free Area:** 60%

### Vert-A-Cade® 400

The vertical line chevron blades of the VAC 400 create a 100% sight barrier from any angle, making it an excellent floor-level screen. VAC 400 also can be used horizontally.

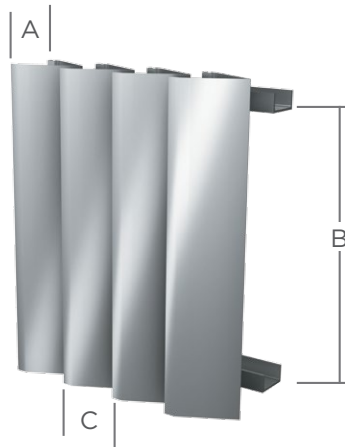

#### Dimensions

**A:** Blade depth: 4"  
**B:** Varies based on wind loading requirements  
**C:** Blade spacing: 4" on center

**Free Area:** 32%

### Vert-A-Cade® 500 and 500M

Clean, crisp lines make the VAC 500 a popular screen that is perfect for hiding rooftop or street-level equipment. The 500M eliminates the back blade for higher free area.

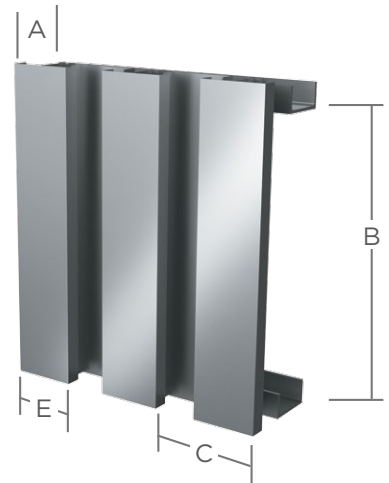

#### Dimensions

**A:** Blade depth: 2"  
**B:** Varies based on wind loading requirements  
**C:** Blade spacing: 5" on center  
**E:** Blade width: 3"

Blade thickness: 0.062"

**Free Area:** VAC 500 20%  
VAC 500M 40%



**Vert-A-Cade® 1000**

The vertical blades of our VAC 1000 offer 100% sight cut-off with high free area, making it an excellent choice for parking garage and mechanical equipment screening.

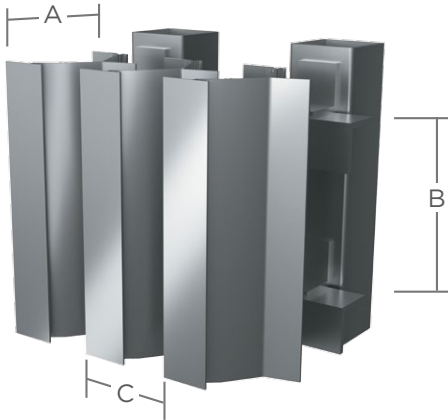

**Dimensions**

- A:** Blade depth: 5.375"
  - B:** Varies based on wind loading requirements
  - C:** Blade spacing: 4.5" on center
- Blade thickness: 0.081"
- Free Area:** 54%

**Vert-A-Cade® 1100**

The VAC 1100's deep Z-shaped blades can be used in either a vertical or horizontal configuration.

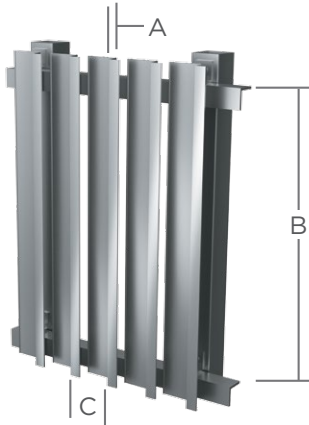

**Dimensions**

- A:** Blade depth: 2.375"
  - B:** Varies based on wind loading requirements
  - C:** Blade spacing: 5" on center
- Blade thickness: 0.081"
- Free Area:** 25%

**Vert-A-Cade® 8000 and 6000**

The VAC 8000 and 6000 both have deep, demi-fin blades, providing a bold sight line on any structure, and can be used both vertically and horizontally.

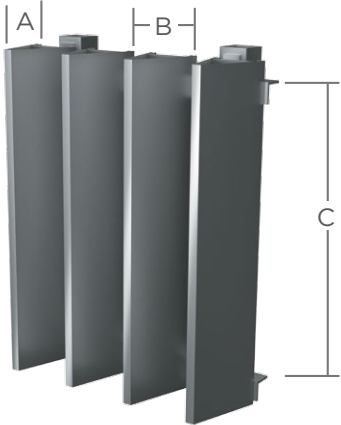

**Dimensions**

- A:** Blade depth for VAC 8000: 8"  
Blade depth for VAC 6000: 6"
  - B:** Blade spacing: 7.875"
  - C:** Varies based on wind loading requirements
- Blade thickness: 0.10"
- Free Area:** 25%



# Why Architectural Grilles & Vision Barriers from Construction Specialties?

When **fit and finish** are your top priorities, accept no substitutes—specify Construction Specialties Architectural Grilles and Vision Barriers.

We offer **solutions**—not just products.

The quality of our geometric grille and vision barrier products can be seen in the **fully engineered system** and connections that include not only the screens but also the clips and fasteners that guarantee the **structural integrity** of your façades.

Compare Construction Specialties Architectural Grilles and Vision Barriers with other suppliers on these additional quality measures:

- **Welds**—To the extent possible, we hide our welds so you'll never notice them on the front of our grilles.
- **Structure**—Our grilles require less substructural gridding, which adds **less weight** with the same fastening reliability.
- **Grilles**—We ship our grilles in factory-assembled panels for **ease of installation**. Verticals ship in pieces or in assembled panels, according to your specifications.
- **Finishes**—We paint the entire structure—not just the front—using our 20-year guaranteed Powder Coat, Kynar 500® and Hylar® 5000 metallic finishes according to your specifications. Choose from our **standard colors** or custom-match a color you're already using.
- **Estimates**—Construction Specialties **bids responsibly**, so our estimate will include everything you'll need for the installation—no surprises.
- **Local tech support**—We have an extensive network of representatives across the United States, with one in every state, and Canada, so we'll come to you for **design, technical, engineering or installation support**.

---

**Construction Specialties** is a leader in architectural specialty products, including Acrovyn® by Design, Acrovyn® Wall and Door Protection, Pedisystems® Entrance Flooring, Floormations, Expansion Joint Covers, Cubicle Track and Curtains, Smoke and Explosion Venting Systems, Architectural Louvers and Sun Controls.

Contact us toll free at **800-631-7379** to talk to our engineers, who will help you select the right grille and anchoring system for your next project. For the nearest Construction Specialties representative or literature and samples, call 800-631-7379 in the United States and **888-895-8955** in Canada, or visit **www.c-sgroup.com**.

---



**Construction Specialties™**

49 Meeker Avenue  
Cranford, New Jersey 07016  
USA 908-272-5200

895 Lakefront Promenade  
Mississauga, Ontario L5E 2C2  
Canada 905-274-3611



Download Our New  
CS Project Locator App

